



INTELLIGENT BATTERY CHARGER

FOR V-LOCK LITHIUM ION BATTERIES ONLY

Model

CVS4X

OPERATING INSTRUCTIONS

Revision 1.1

Please read these instructions concerning your safety

BLUESHAPE lithium-ion battery chargers have been designed to provide a superior performance by managing relatively high currents during their operation in order to reduce charging time.

As may be expected, the chargers become warm during operation and it is therefore very important to keep their ventilation openings unobstructed.

Moreover, please follow the safety instructions below.

- Protect the equipment from humid environments. Avoid any contact with water or other fluids. Do not use if any liquid has been accidentally spilled inside the equipment .Contact qualified service personnel for inspection or repair
- Clean only by using a dry cloth
- Unplug when not in use and avoid power surges
- Read the supplied instructions thoroughly and keep handy
- Avoid setting up near heat sources such as fire places, radiators, stoves or other heat generating equipment
- NEVER use without proper grounding
- Protect the AC mains power plug, connector and cord
- If the equipment develops a fault, have it repaired by qualified service personnel only
- NEVER block the ventilation openings or obstruct cooling fan air flow
- Use only as instructed by the manufacturer
- Do not remove cover or dismantle the apparatus. No user-serviceable parts inside

WARNING

THIS EQUIPMENT MUST BE EARTHED



**TO PREVENT FIRE OR SHOCK HAZARD
DO NOT EXPOSE THE UNIT TO RAIN OR
MOISTURE**

2

**TO AVOID ELECTRIC SHOCK, DO NOT OPEN THE
APPARATUS AND ALWAYS REFER ANY SERVICING TO
QUALIFIED PERSONNEL**



The user is being alerted of the importance of going through the literature accompanying this product and familiarising himself with the important safety and operating instructions, included.

BLUESHAPE CHARGERS ARE INTENDED FOR OPERATION WITH LINE VOLTAGES BETWEEN 100V AND 240V AC AND LINE FREQUENCIES BETWEEN 43Hz AND 60 Hz

The equipment is being supplied with a compatible AC mains power cord. In the case when the UK plug is fitted, this plug is equipped with a 13A replaceable fuse.

Package contents

- CVS4X simultaneous four position charger
- AC power cord
- Safety operating instructions
- USB data cable to be used with BSCVMon software downloadable from our website at the following address:
<http://www.blueshape.net/index.php/products/software/bscvmon.html>

CVS4X graphic description – Front/right side



1. Battery LED indicators (see page 11 for explanation)
2. AUX output LED indicator (see page 12 for explanation)
3. Carrying handle
4. Ventilation inlets
5. Release buttons
6. Battery #3 and #4 charging bays (Battery #1 and #2 charging bays are on the opposite side)

CVS4X graphic description – Rear/left side



1. Ventilation outlets
2. Data connector
3. AUX output connector (13.8V 110W)
4. Ventilation inlets
5. Release buttons
6. Battery #1 and #2 charging bays (Battery #3 and #4 charging bay are on the opposite side)
7. AC Mains input, 100V-240V
8. Mains switch

Introduction

The BLUESHAPE series of intelligent lithium ion battery chargers has been specifically designed for fast and reliable charging of the BLUESHAPE V-lock battery range. All charger models are capable of delivering up to 4.9Amps in constant current mode making them particularly suitable to users who require a fast turnaround from their batteries. For the users' convenience, the external dimensions have been kept as compact as possible for better portability.

Properties of the CVS4X

- Elegant and robust design. Ideal for indoor use
- Sophisticated electronics for accurately detecting the charging state
- Simultaneous battery charging
- Charging power optimisation for maximum charging performance
- Three-colour LED indicators for each individual charge-station monitoring
- Pre-charge function for protecting heavily discharged cells against high currents until their voltages rise to a safe level.
- Maximum compactness and space utilisation
- IPCS and CTP Features (*see next pages*)
- Powerful auxiliary output at 13.8V / 110W through 4-pole XLR

Battery charging and performance features

The electronic circuitry provides a very accurate lithium ion charge algorithm. Initially, the chargers will only apply a pre-charge current of a few milli-amperes to batteries that are heavily discharged. This same current enables the charger to detect the current battery state. Once the cells inside the batteries reach a safe level, the full (maximum) charging current is delivered until the battery reaches almost 80% state of charge. After this, a constant voltage phase begins with the charging current decaying slowly until full cut-off.

The following table describe the charging time (in minutes) with regards to battery model and number of batteries installed. The approximate charging time refers to charging batteries from empty.

Battery model	up to 2 batteries installed (all charging simultaneously)	more than 2 batteries(bat. 1 to 2 charging simultaneously first, followed by bat. 3 to 4 charging simultaneously after)
BV065	91	182
BV090	126	252
BV100HD	126	252
BV150	207	414
BV180	248	496
BV190HD	273	546

BV225	310	620
BV270HD	372	746

IPCS and fast charging

The BLUESHAPE CVS4X charger features the highest charging current for a Li-Ion charger in the broadcasting sector.

This results in currently the shortest possible battery charging time. BLUESHAPE Li-Ion BV battery series allow fast charging due to several intrinsic features such as pre-charge protection and cell balancing; avoiding cell damage and life-cycle shortening, as demonstrated by the life-cycle performances.

Additionally, the CVS4X charger supports and enhances these features with **IPCS**, a 2-step Intelligent Pre-Charge System.

Since fast charging can damage cells if not properly applied, especially with low voltage (discharged) cells, appropriate care must be taken. The 2-step procedure implemented by IPCS, initially boosts very low voltage cells to a state where charge can be applied with a medium-low current without damage, then starts to charge with a 300mA current for a while. Finally, when the pack reaches a reasonable voltage state, it speed-up the charge process by going to full throttle.

The operation implemented by IPCS is only applied if the prevailing cells-state need it, and normally takes a few minutes, depending on the state of discharge of the cells.

The operation implemented by IPCS is outlined in the chart below.

IPCS 2-step Intelligent Pre-charge System

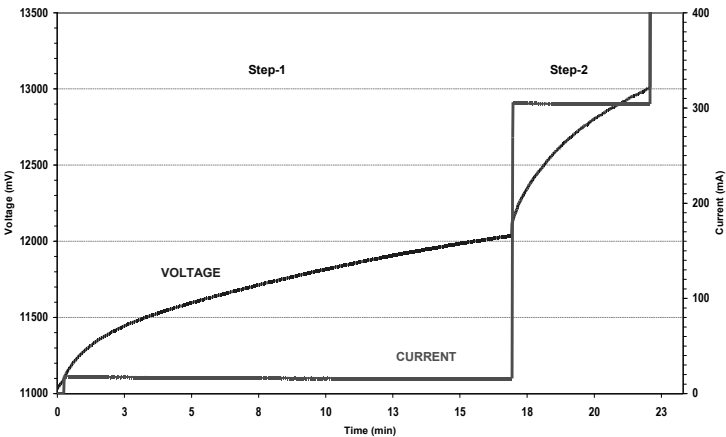

CTP: flexibility of operation and charger reliability

Due to the high charging currents developed by the CVS4X charger, heat control is an issue for a travel charger, especially if the travel charger is used in potentially hot environments such as inside a car or a van.

To improve the reliability of the device without compromising its usage flexibility, BLUESHAPE has developed an innovative feature; **CTP** (Charger Thermal Protection) that allows the electronics to work out the best possible charge profiles without causing damage, even in adverse temperature conditions.

In case of the charger internal temperature reaching a high level, the charging current is automatically reduced to avoid possible damage caused by internal overheating. When the charging speed is reduced, the internal temperature starts to descend. As soon as the temperature reaches a safe level, normal charging speed is resumed.

Through indoor usage, CTP features do not normally intervene (unless the air convection flow path is obstructed or the internal cooling fan is damaged).

The operation implemented by CTP is outlined in the chart below.

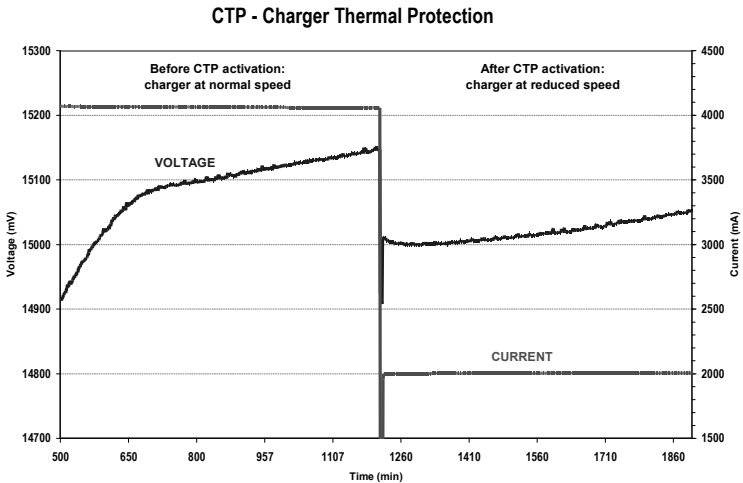

Operating Instructions

This charger can take up to 4 batteries and charges them as follows:

- the channel pair 1-2 (left side of the charger) is independent from pair 3-4 (right side). The charge is managed simultaneously between the two pairs.
- within the same pair (1-2 or 3-4), the batteries are charged sequentially: first available/ first charged

How to proceed:

- Plug the AC power cord provided into the charger AC input
- Plug and switch on the AC mains supply
- Insert a battery inside any one of the four V-plate adapters as shown (see picture)

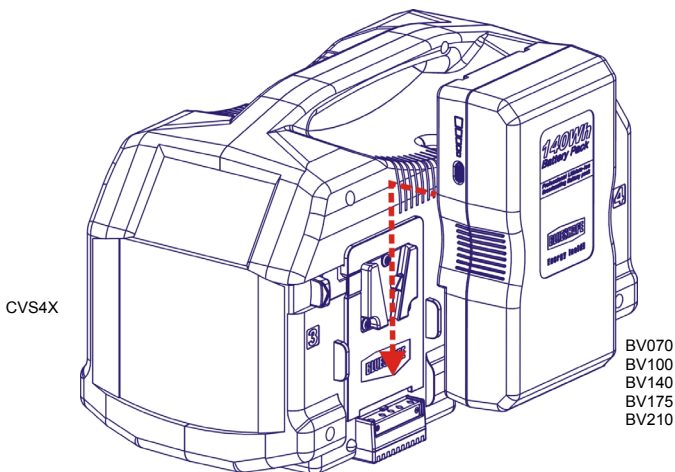

Insert in the direction of the arrow

- Observe the LED. In addition, the charge status may be read in 20% steps through the BLUESHAPE battery LED array.
- Leave the battery to charge for the appropriate time (see table on page 6)
- Remove the battery when the LED becomes steady green as shown (see picture on next page)

In the case when you want to charge 2 or more batteries, insert the additional batteries into the available V-plate adapters.

CVS4X

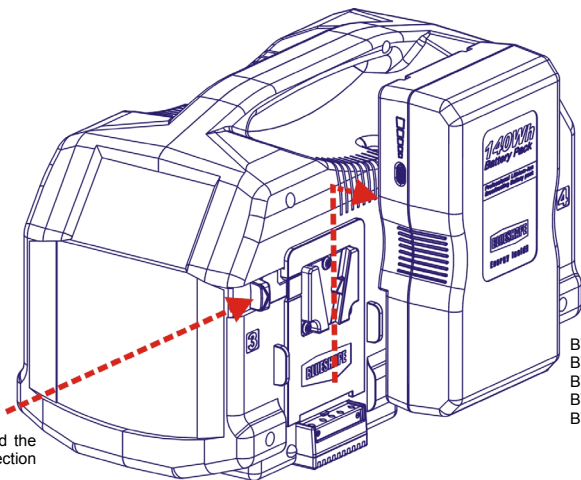

BV070
BV100
BV140
BV175
BV210

1) Push and hold the button in the direction of the arrow

2) Pull out the battery in the direction of arrow

Please note that:

- If the battery is installed on the same side of the battery on charge, it will only start charging when the first one has finished charging.
- If the battery is installed on the opposite side, it will start charging immediately and independently.

The LEDs will always display the correct status of the charging process for each battery.

In the case when an accessory is plugged into the accessories XLR, the charging process will be suspended. The AUX LED will light up and the other battery LEDs will show 'WAITING'. Once the accessory has been unplugged, the charger will continue the previous charging sequence, from the original point of interruption. PLEASE NOTE THAT THE MAXIMUM LOAD THAT CAN BE CONNECTED TO THE XLR OUTPUT MUST NOT EXCEED 110W.

ADDITIONAL SAFETY NOTES

Chargers and/or batteries may become hot during charging. This is normal. Please consult your BLUESHAPE dealer if you notice that either a charger or a battery, become excessively hot during the charging operation.

Be careful not to block the equipment's ventilation outlets.

Never insert any metallic or any other objects inside the equipment through the ventilation openings or otherwise.



Battery LED indications

#	OPERATING MODE	TIMEOUT	LED INDICATION
1	BATTERY DETECTION Battery detected while the other on the same pair is already charging		BATTERY WAITING: GREEN: 1sec ON/1sec OFF
2	BATTERY NOT ALLOWED 10Kohm < ID resistor < 60Kohm		BATTERY NOT ALLOWED: GREEN: 500ms/RED: 500ms
3	BATTERY EVALUATION i) Total pack voltage < 8000mV ii) $I < 10\text{mA}$ If the charging does not rise within 30sec, the battery does not accept charge iii) Single cell voltages < 2800mV $10\text{mA} < I < 50\text{mA}$ iv) Single cell voltages > 2800mV Total pack voltage < 13000mV $50\text{mA} < I < 300\text{mA}$	3600sec 1200sec	VOLTAGE TOO LOW: RED flashing 500ms ON/500ms OFF BATTERY FAILURE: Steady RED PRECHARGE-1: ORANGE flashing 500ms ON/500ms OFF PRECHARGE-2: ORANGE flashing 250ms ON/250ms OFF
4	CONSTANT CURRENT MODE $13000\text{mV} < V < 16750$, $I = \text{max } 4.9\text{A}$	18000sec	CC-MODE: Steady ORANGE
5	CONSTANT VOLTAGE MODE $V > 16750\text{mV}$ $150\text{mA} < I < 4900\text{mA}$	10800sec	CV-MODE: ORANGE 500ms/ GREEN 500ms
6	FULL CHARGE $V \cong 16800\text{mV}$ $I \cong 150\text{mA}$		FULL CHARGE: Steady GREEN
7	OTHER INDICATIONS In the case of premature charge termination, the charger retries to charge the battery every 30 seconds. If after 10 minutes, there is still no response, the indication is changed into 'BATTERY FAILURE'		PREMATURE CHARGE TERMINATION: RED: 250ms ON/100ms OFF / 250ms ON /1sec OFF (2 blinks + 1 pause) BATTERY FAILURE: Steady RED

AUX output LED indications

#	OPERATING MODE	LED INDICATION
1	The AUX output is correctly powered up: $10\text{mA} < I < 8.2\text{A}$	AUX OK: AUX LED Steady GREEN
2	The AUX is self-protected if a load is connected and an excessive current is absorbed: $I > 8.2\text{A}$	SHORT-CIRCUIT: AUX LED Steady ORANGE
3	An Overload condition may occur when the AUX is powered up and an excessive current is drained as follow: i) $8.2\text{A} < I < 9.5\text{A}$, for 30sec ii) $9.5\text{A} < I < 13\text{A}$, for 1sec iii) $I > 13\text{A}$	OVERLOAD1: AUX LED+BAT2+BAT4 Steady RED OVERLOAD2: AUX LED Steady RED OVERLOAD3: AUX LED Steady ORANGE

Technical specifications

Type	Constant current and voltage control system with timer interventions
CC-MODE: Output current	4900mA \pm 1%
CC-MODE: Vmax	16800 \pm 50mV (0.3%)
CV-MODE: Vmax	16800 \pm 50mV (0.3%)
CV-MODE: Cutoff current	150mA \pm 10mA
Short circuit protection	Available
Overcharge protection	Available
Overtemperature protection	Available
LEDS	3 colour type for BAT1, BAT2, BAT3, BAT4 and AUX
Special features	IPCS and CTP
Auxiliary power	13.8V 110W (max)
Power supply	AC mains 100V - 240V ~, 47 - 63 Hz autoselect
Fuse	1 x 220V 2.5A (5x20mm quick blow) + 1 spare
Power consumption	100W max / 90W typical
Operating temperature range	0°C - 45°C
Storage temperature range	-20°C - 65°C (-4°F - 149°F)
Dimensions	170 x 150 x 280 mm
Weight	2200g

The CVS4X underwent and has successfully passed CE certification.

Notes concerning charger usage with BLUESHAPE battery packs

It is recommended that users always have at least another spare battery readily available.

It is preferable to charge batteries immediately before use. Some loss from self-discharge would result if the batteries are charged several weeks in advance of their intended use. However, this slight loss can be topped up at any time without any degradation of battery performance (no memory effect)

It is recommended to store batteries in a cool and dry place. Charging should be done at temperatures above 0°C and below 45°C.

Slight heating of the battery is expected to occur during charge. However if for some reason, the pack temperature reaches 60°C, then the charge activity is suspended.

The pack resumes normal charging once the temperature drops back to below 50°C. This is a safety feature incorporated in all BLUESHAPE battery packs.

Warranty

BLUESHAPE chargers are warranted to be free from defects in materials, workmanship and functionality for a period of 18 months commencing from the date of purchase.

This warranty shall not apply to any products or parts of, that have been subjected to misuse, negligence, accidental or abnormal conditions of operation.

The buyer should always contact the place of purchase for any return of defective product. It is important that the buyer provides us with as much information as possible about the failure being claimed.

In the event of product failure for which warranty applies, we will repair or replace the product free of charge. In these cases, all expenses including transport charges will be borne by us.

In the case where the failure has been caused by one of the causes explained above, repairs should be billed at a nominal cost. Prior to the carrying out of any repairs, we will inform the customer of the estimated costs of these repairs.

These warranty conditions are the only ones applicable to our products and overrule any other expressed or implied warranties. We shall not be held liable for any damages resulting from warranty statements other than those contained in this declaration.

In all warranty claims, the buyer must reproduce the original purchase invoice.



NEW CELL TOP Srl
VIA LIGURIA 4-6,
42124 REGGIO EMILIA, ITALY
TEL. +39 0522 518556
FAX. +39 0522 277084
WEB: www.blueshape.net
EMAIL: info@blueshape.net